



GoodPack 1-GPPW-1520

Semi-Auto Stretch Wrapping Machine

The GoodPack GPPW1520 has been designed and built with economy, efficiency and safe operation in mind. These stretch wrapping machines will give you all of the features you need to wrap pallet loads quickly and efficiently. The GPPW1520 dramatically increase efficiency and profitability through lower film cost per load compared to manual (hand) stretch wrapping.



Features:

- Eliminate the need for labour intensive, inefficient manual hand wrapping.
- Rugged steel construction for long-term reliability
- Photocell eye for automatic height detection
- Forklift relocation slots for easy machine transportation
- Automatic and manual wrapping programs.
- Includes ramp for pallet truck access
- User friendly 'Soft Touch' controls

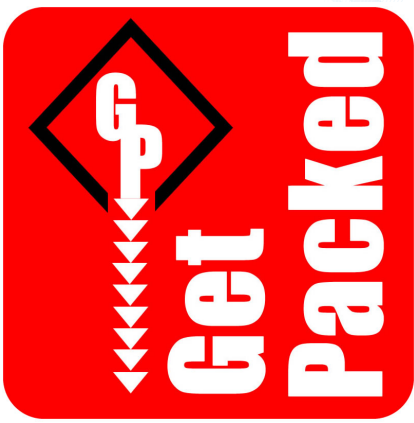

Standard Features

- Electronic screen with 'Soft Touch' control
- Variable film carriage and turntable speeds
- Forklift relocation slots
- Photocell eye for automatic height detection
- Automatic and Manual wrapping programs
- Soft-start and stop turntable drive
- Ramp can be fixed to the table at 3 different angles
- Includes pallet truck access ramp
- Adjustable friction brake stretch system
- Heavy-duty industrial chain driven turntable
- Safety crush prevention device fitted to carriage
- Standard 12 month warranty

Available Options

- Larger 1800, 2200mm turntable size
- Heavy duty 2000 kg turntable.
- Higher wrapping height - 2700mm.
- Black Photocell eye to detect black or dark products.

Technical Data

Max height of wrapping	2200 mm
Max pallet size	1200 x 1200 mm
Turntable diameter	1520 mm
Turntable speed	1-10 RPM
Stretch film size	500 mm
Load capacity	1500 kg
Power supply	240v, single phase
Warranty	1 Year
Machine weight	650 kg

Includes pallet truck access ramp

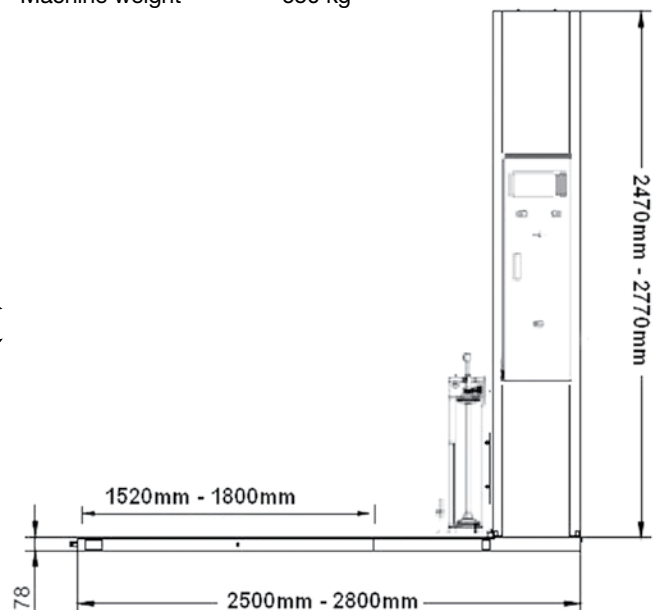
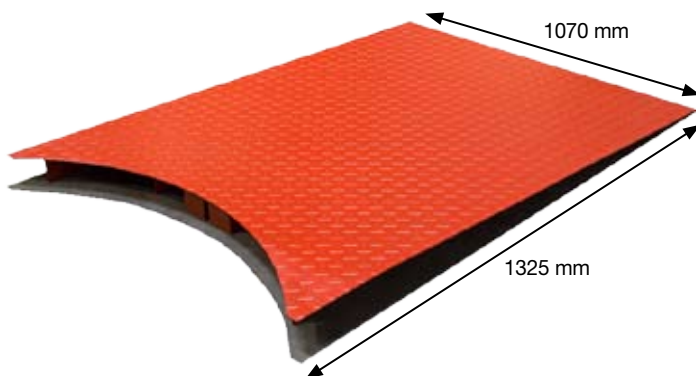

02 9452-3566

sales@getpacked.com.au