

One Hand Possible with practice, Two hands probable to begin!

STEP 1 Travel

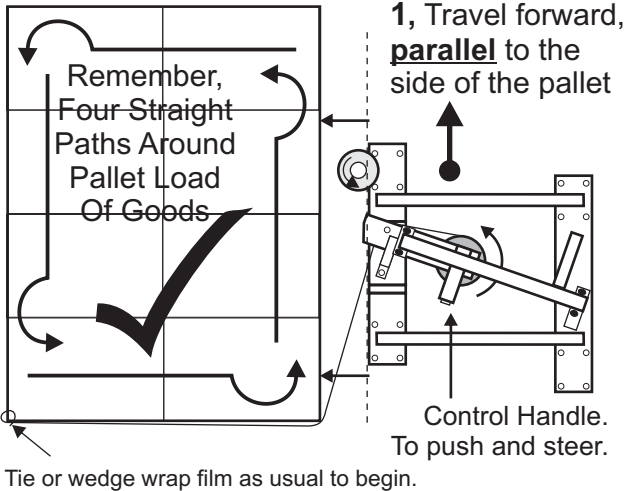

STEP 2 Pivot Point

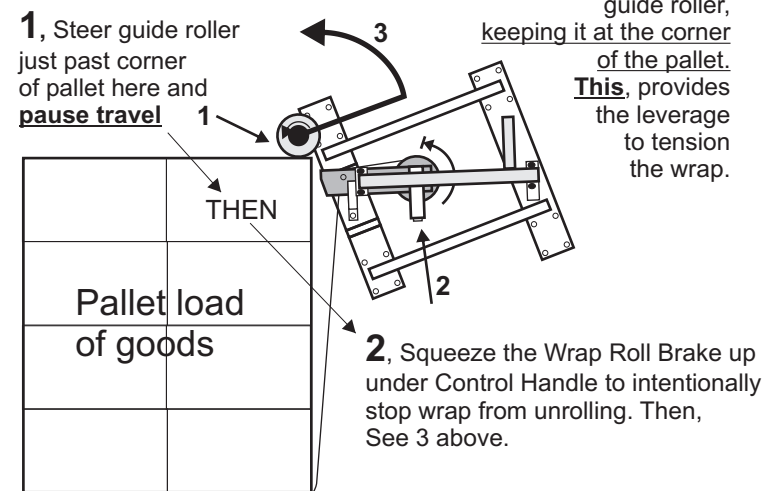

STEP 3 Tension

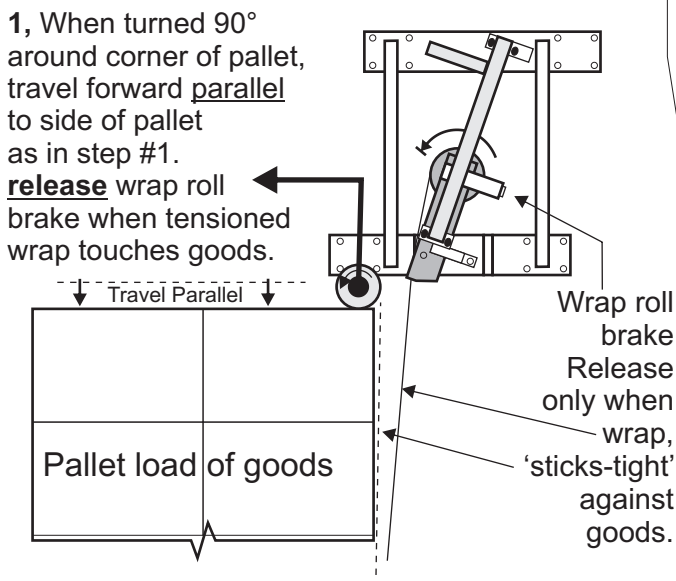

STEP 4 Raise Wrap Height

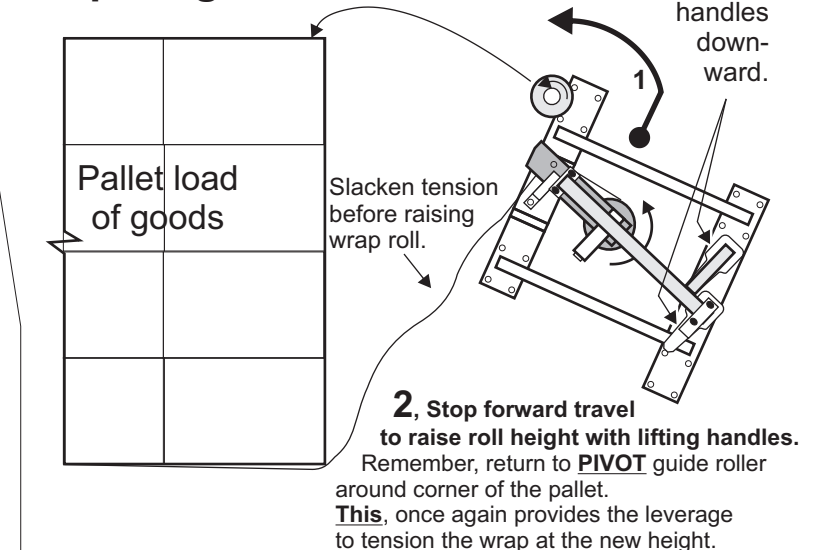

STEP 5 Cut Off

- 1, Steer guide roller around last corner of pallet and touch tensioned wrap against goods. Angle Wrappa so that film is tight against Wrap Cutter Tube and pull sharply upward the knurled cutter knob to cut off wrap.

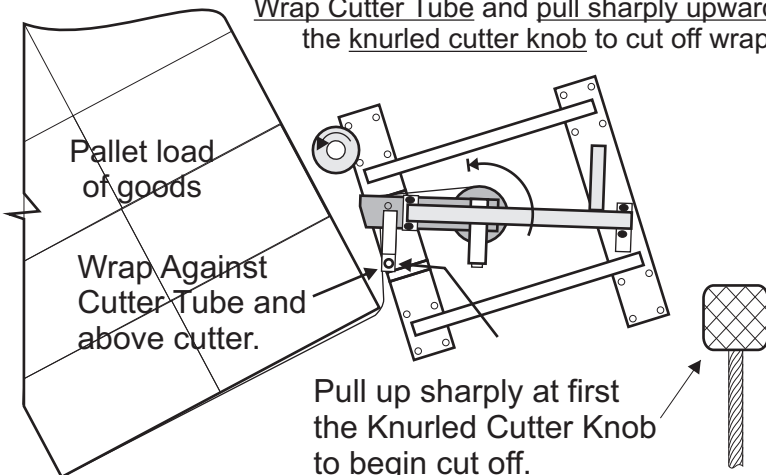

WRAPPA PART NAMES

